

VHF.50.SS



50L Volume Capacity

Internal Hopper Feeder



SOP Recipe Management

Store up to 10 Pre-set



Large Diameter Input with 12" Funnel

DN65 Tri-Clamp 65mm Input Diameter



Food Safe Design

304/316 Stainless Steel Construction Smooth

📞 US: +1 (603) 800 1799

@ sales@sampleautomation.com



Features

- Stainless Steel Hopper Assembly
- Stainless Steel Agitator with Variable Speed
- Stainless Steel Flight Auger with Variable Speed
- Smooth Finished Welds
- Direct P19 Attachment
- Sanitary Silicone Reducer Attachment
- Food Grade 304 & 316 Stainless Steel Frame

Electrical

- 110V Single Phase 50/60Hz -1725 watt, 8Nm
- 220V Double Phase 50/60Hz - 2350 watt, 10Nm
- 400V Three Phase 50/60Hz - 5000 watt, 30Nm
- Nema 34 - 12Nm 20A 24VDC Stepper Motor

Controls

- 5.7" Touch Screen HMI
- Emergency Stop and Isolation Switch
- Automated Auxiliary Controls
- SOP Recipe Speed and Setting Controls
- Password Setting Controls
- Feeder Exit Port Laser Sensor
- Collection Container Point Sensor

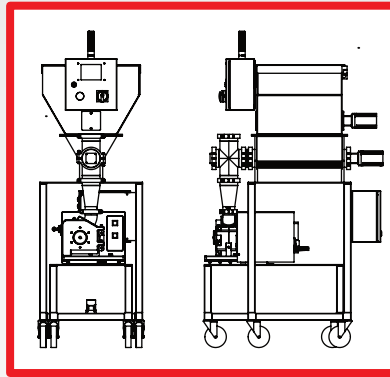

Dimensions:

- VHF.50.19: without Cyclone (102cm L x 60cm W x 178cm H)
- Weight: 175Kg

